

ROBOTIC ARM EXPLODED
SCALE 1 / 2

GENERAL NOTES:

-ALL ROUNDS AND FILLETS .06 UNLESS OTHERWISE SPECIFIED

-ALL CHAMFERS .02 X .02 UNLESS OTHERWISE SPECIFIED

PARTS LIST				
ITEM	QTY	PART NUMBER	MATERIAL	DESCRIPTION
1	1	BASE	ALUMINUM	
2	1	ARM 1	ALUMINUM	
3	1	ARM 2	ALUMINUM	
4	1	BASE CAP	ALUMINUM	
5	1	ELBOW CAP	ALUMINUM	
6	1	SLIDING TUBE END	STAINLESS STEEL	
7	1	SLIDING TUBE	STAINLESS STEEL	
8	1	VACUUM CAP	ALUMINUM	
9	1	VACUUM CONNECTOR	STAINLESS STEEL	
10	1	VACUUM CUP	RUBBER	
11	1	VACUUM HOSE	PLASTIC	.25" OD X .125"ID X 10"LONG

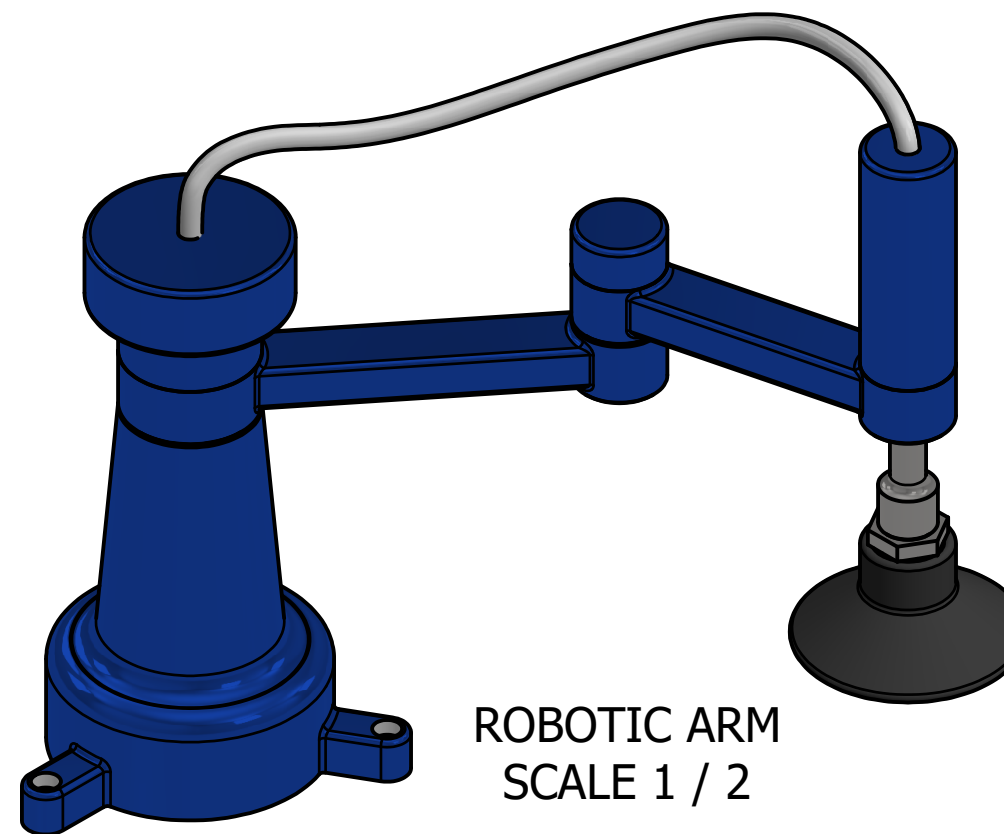

ROBOTIC ARM
SCALE 1 / 2

LEGEND:

- ∅ DIAMETER
- R RADIUS
- ° DEGREES
- ∇ DEPTH
- COUNTER BORE



DIGITAL DESIGN
GRAPHICS
TECHNOLOGY

WWW.DDGT.NET



Connor McCall
Designer
(707)287-6180
connorm.1440@gmail.com
www.ddgt.net/studentpages/cmccall

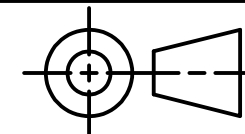

TOLERANCES UNLESS SPECIFIED:
DECIMAL INCHES:
X = ±.020
XX = ±.010
XXX = ±.005
FRACTIONAL ±1/64"
ANGLES ±1 DEGREE
SURFACES 32✓

COURSES: DDGT241

INVENTOR DRAWING NAME:
ROBOTIC ARM

FIG #: 1058

DRAFTER: C. MCCALL

DATE: 2/20/2020

SCALE: AS NOTED

PAGE #: 1 OF 4

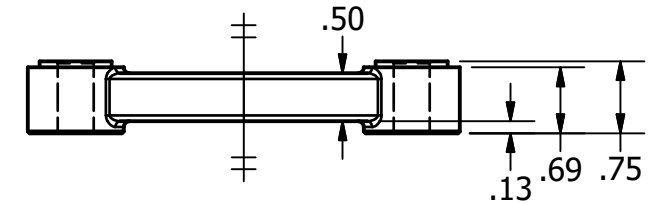
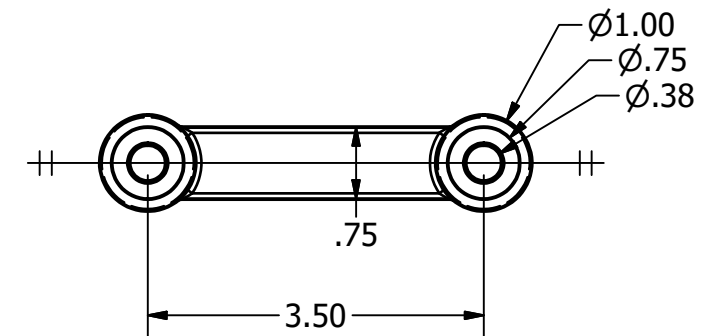
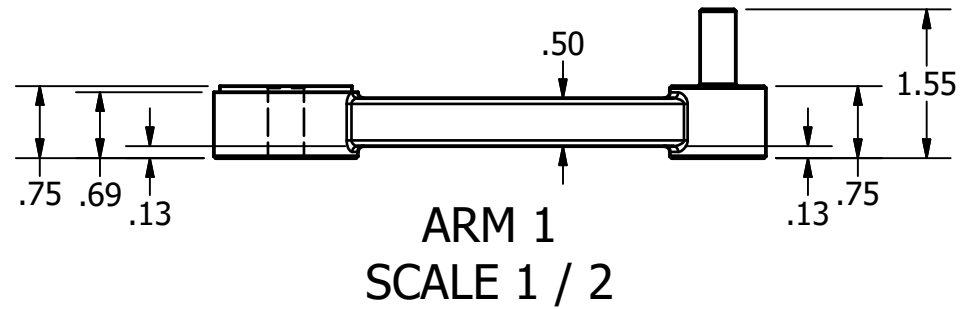
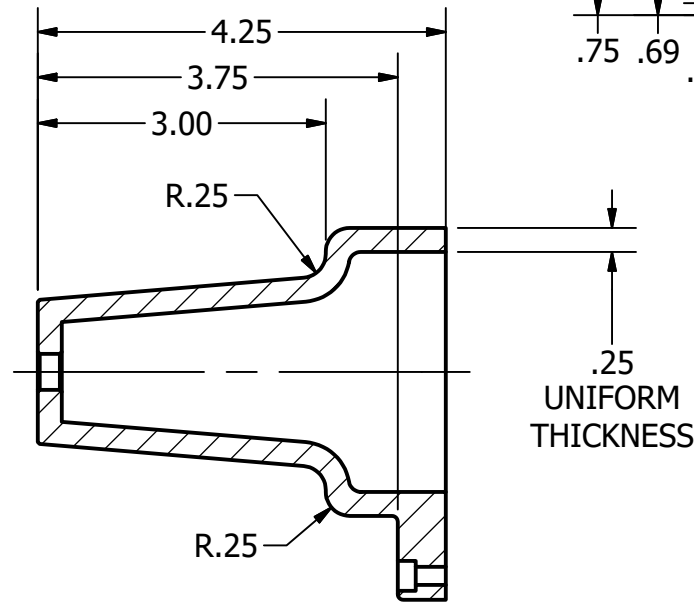
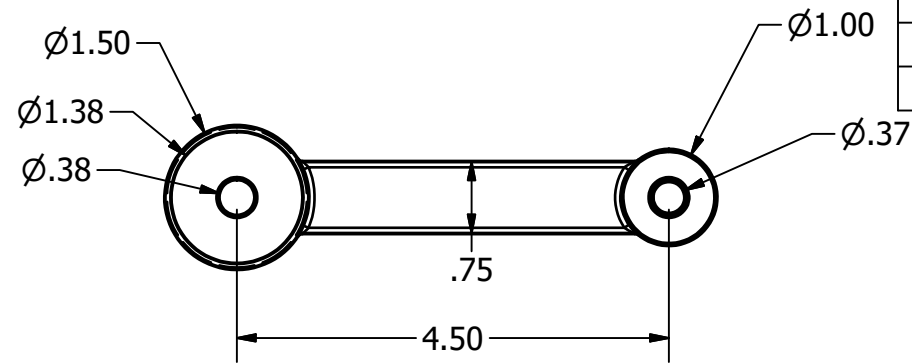
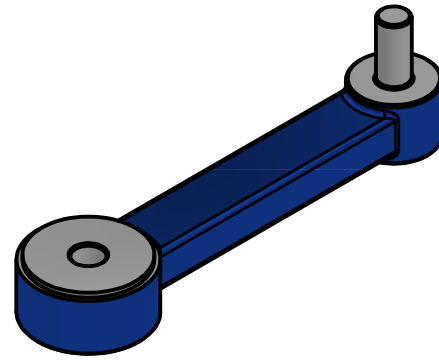
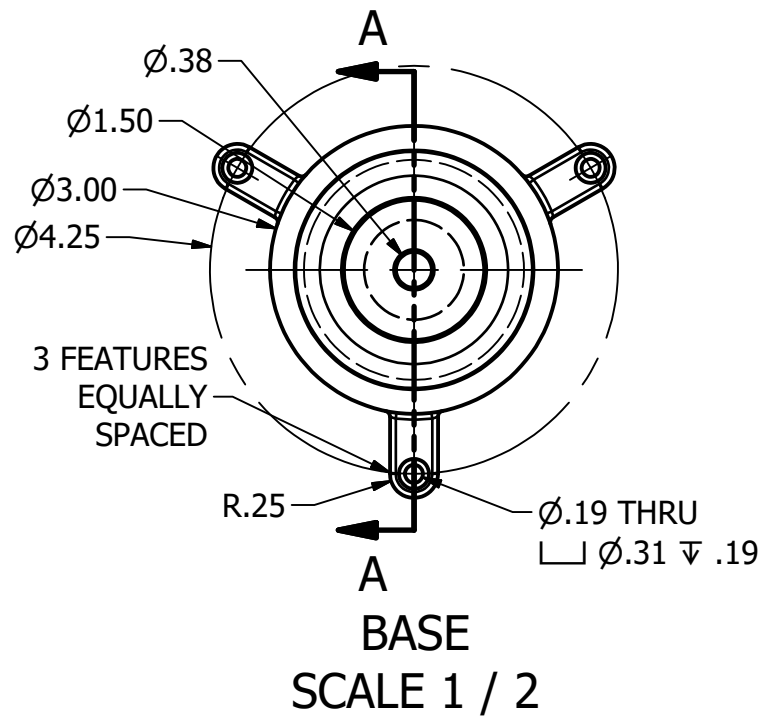
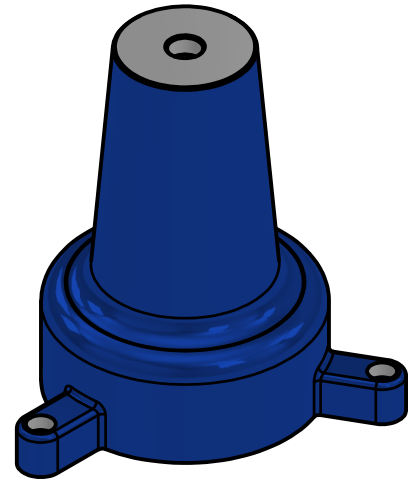

ARM 2
SCALE 1 / 2

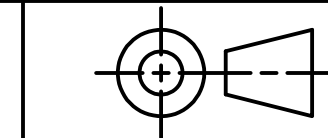

TOLERANCES UNLESS SPECIFIED:
 DECIMAL INCHES:
 X = ±.020
 XX = ±.010
 XXX = ±.005
 FRACTIONAL ±1/64"
 ANGLES ±1 DEGREE
 SURFACES 32 ✓

PARTS LIST		
ITEM	QTY	PART NUMBER
1	1	BASE
2	1	ARM 1
3	1	ARM 2

COURSES:	DDGT241
INVENTOR DRAWING NAME:	ROBOTIC ARM
FIG #:	1058
DRAFTER:	C. MCCALL
DATE:	2/20/2020
SCALE:	AS NOTED
PAGE #:	2 OF 4

GENERAL NOTES:

-ALL ROUNDS AND FILLETS .06 UNLESS OTHERWISE SPECIFIED

-ALL CHAMFERS .02 X .02 UNLESS OTHERWISE SPECIFIED



DIGITAL DESIGN
 GRAPHICS
 TECHNOLOGY

WWW.DDGT.NET



Connor McCall
 Designer
 (707)287-6180
 connorm.1440@gmail.com

www.ddgt.net/studentpages/cmccall

PARTS LIST		
ITEM	QTY	PART NUMBER
4	1	BASE CAP
5	1	ELBOW CAP
6	1	SLIDING TUBE END
7	1	SLIDING TUBE

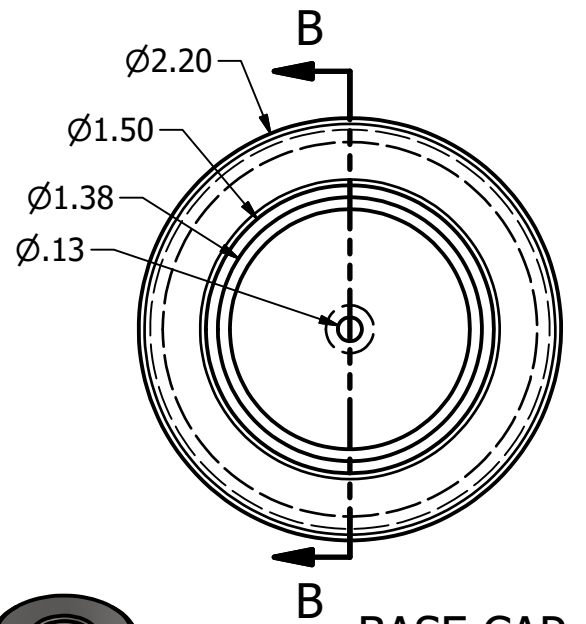
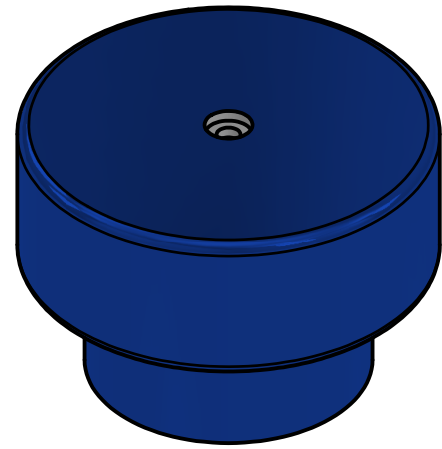

BASE CAP
SCALE 1 : 1

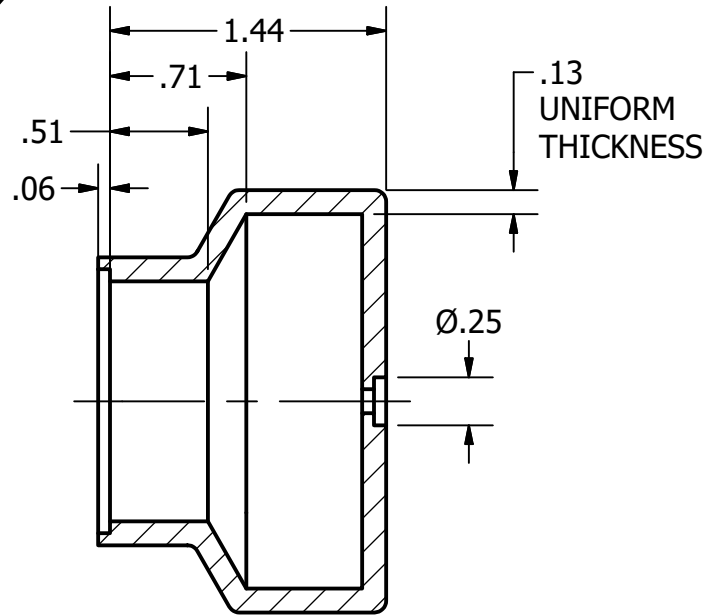

SECTION B-B
SCALE 1 : 1

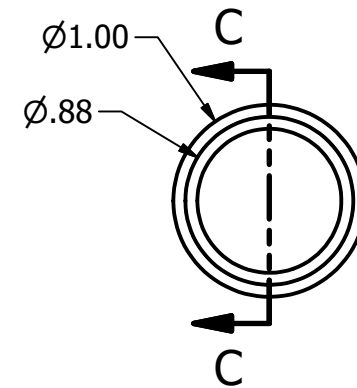
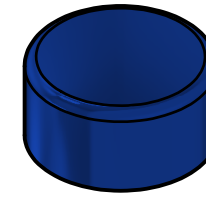

ELBOW CAP
SCALE 1 : 1

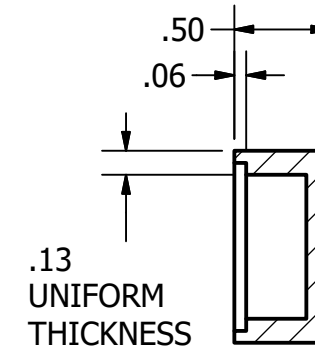

SECTION C-C
SCALE 1 : 1

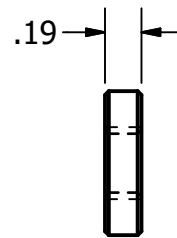

SLIDING TUBE END
SCALE 1 : 1

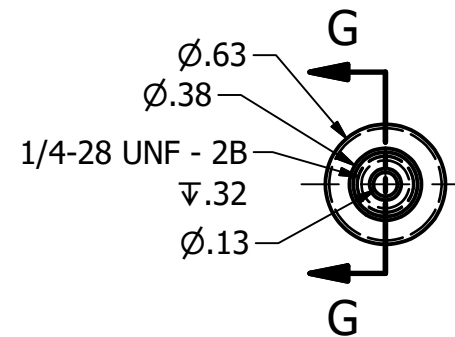
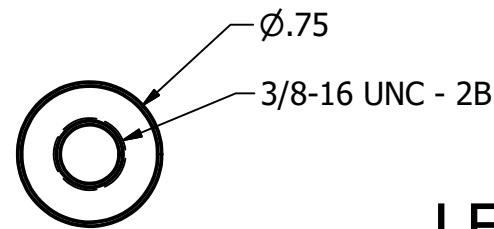

SLIDING TUBE
SCALE 1 : 1

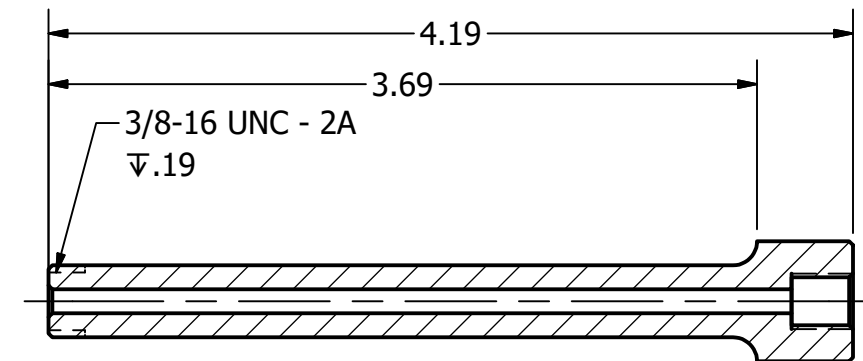

SECTION G-G
SCALE 1 : 1

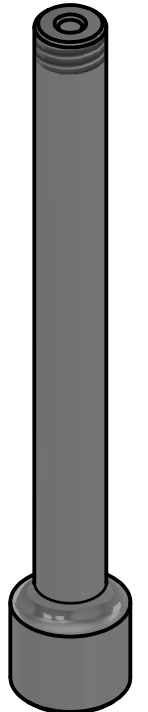

LEGEND:

- ∅ DIAMETER
- R RADIUS
- ° DEGREES
- ∇ DEPTH
- ┌ COUNTER BORE

GENERAL NOTES:

-ALL ROUNDS AND FILLETS .06 UNLESS OTHERWISE SPECIFIED

-ALL CHAMFERS .02 X .02 UNLESS OTHERWISE SPECIFIED



DIGITAL DESIGN
GRAPHICS
TECHNOLOGY

WWW.DDGT.NET



Connor McCall
Designer
(707)287-6180
connorm.1440@gmail.com
www.ddgt.net/studentpages/cmccall

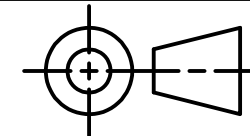

TOLERANCES UNLESS SPECIFIED:
DECIMAL INCHES:
X = ±.020
XX = ±.010
XXX = ±.005
FRACTIONAL ±1/64"
ANGLES ±1 DEGREE
SURFACES 32✓

COURSES: DDGT241

INVENTOR DRAWING NAME:
ROBOTIC ARM

FIG #: 1058

DRAFTER: C. MCCALL

DATE: 2/20/2020

SCALE: AS NOTED

PAGE #: 3 OF 4

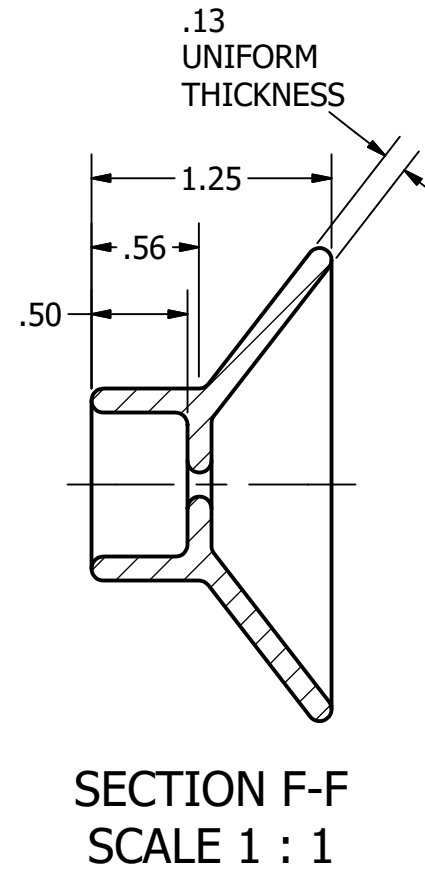
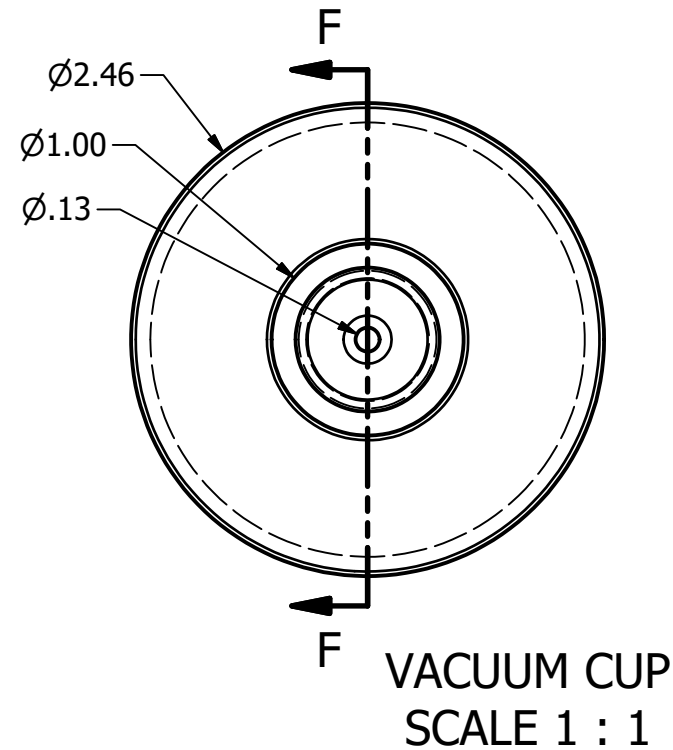
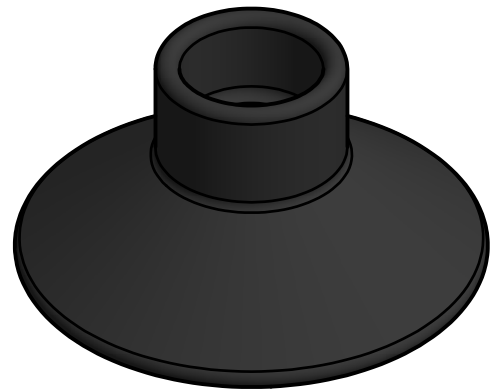

PARTS LIST		
ITEM	QTY	PART NUMBER
7	1	SLIDING TUBE
8	1	VACUUM CAP
9	1	VACUUM CONNECTOR
10	1	VACUUM CUP

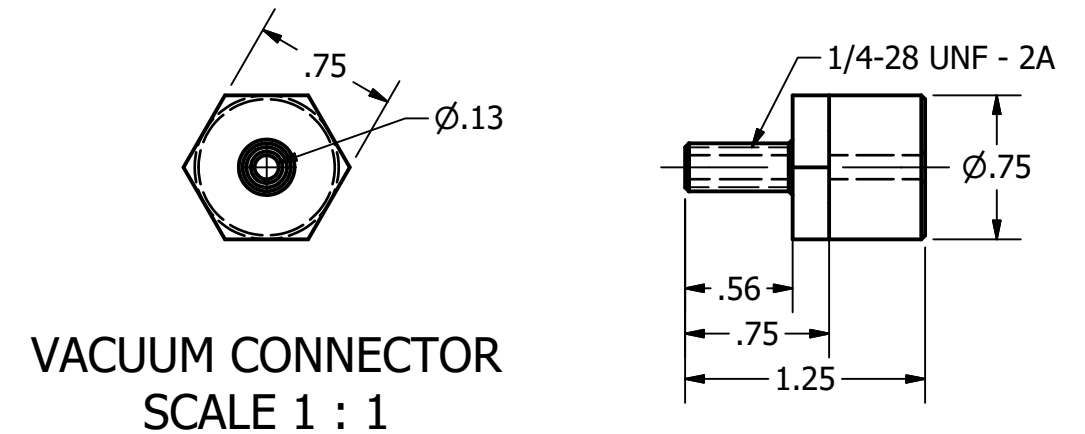
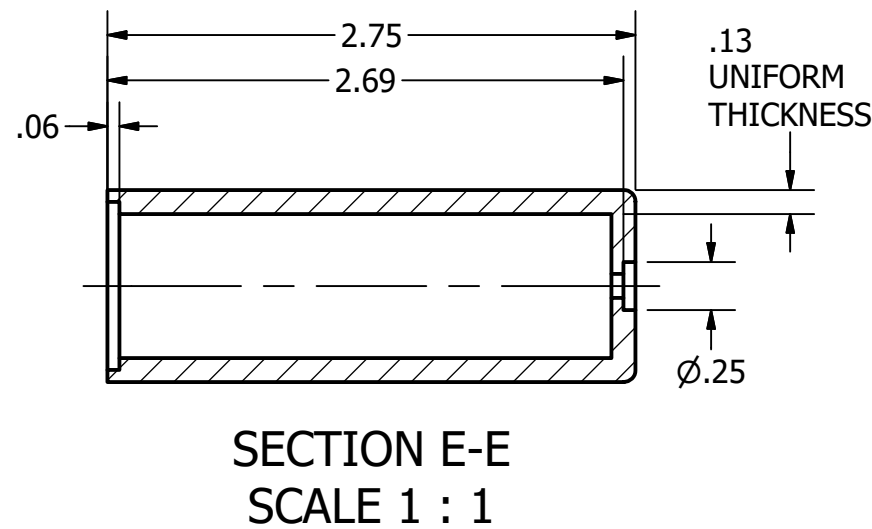
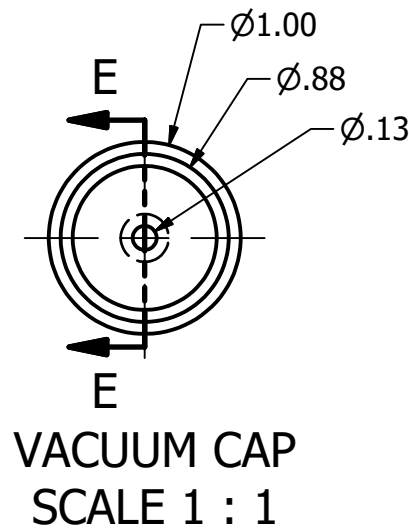
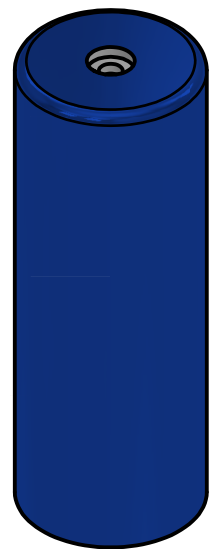
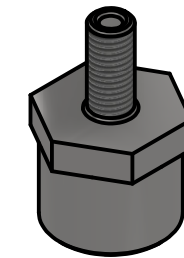

GENERAL NOTES:

-ALL ROUNDS AND FILLETS .06 UNLESS OTHERWISE SPECIFIED

-ALL CHAMFERS .02 X .02 UNLESS OTHERWISE SPECIFIED

LEGEND:

- Ø DIAMETER
- R RADIUS
- ° DEGREES
- ∇ DEPTH
- COUNTER BORE



DIGITAL DESIGN
GRAPHICS
TECHNOLOGY

WWW.DDGT.NET



Connor McCall
Designer
(707)287-6180
connorm.1440@gmail.com
www.ddgt.net/studentpages/cmccall

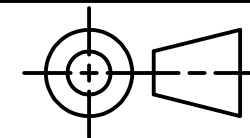

TOLERANCES UNLESS SPECIFIED:
DECIMAL INCHES:
X = ±.020
XX = ±.010
XXX = ±.005
FRACTIONAL ±1/64"
ANGLES ±1 DEGREE
SURFACES 32 ✓

COURSES: DDGT241

INVENTOR DRAWING NAME:
ROBOTIC ARM

FIG #: 1058

DRAFTER: C. MCCALL

DATE: 2/20/2020

SCALE: AS NOTED

PAGE #: 4 OF 4